



DESCRIPTION

The Model 521 is an **Automatic Engine Control Module** designed to automatically start and stop the engine. It will indicate the operational status and fault conditions, automatically shut down the engine and indicate the engine failure by a flashing LED on the front panel. Other simultaneous faults are indicated by steady LED.

Selected operational sequences, timers and alarms can be altered by the customer by using either the 807 hand held calibration unit or a PC and the 808 interface. This also provides the operator with 'real-time' diagnostic facilities to monitor the operation of the system either locally or remotely. Remote PC-controlled engine starting and stopping is also featured.

Operation of the module is via a three position rotary switch (key-switch option available) mounted on the front panel with STOP, AUTO and MANUAL positions.

Microprocessor control allows for **enhanced operation**. The module features a comprehensive list of timers and pre-configured sequences. This allows complex specifications to be achieved

Configurable expansion facilities are provided.

Relay outputs are provided for:

- Fuel Solenoid Output
- Start Output
- 3 configurable outputs.

Normally the relays are configured as pre-heat, load transfer and alarm outputs. However the relay function is configurable to activate on a range of 32 different functions, conditions or alarms. The relays supply positive plant supply out.

Configurable inputs are available for:

- Low Oil Pressure
- High Engine Temperature
- Remote Start.

This allows the module to function with N/O or N/C switches. Four fully configurable auxiliary inputs are provided to give protection expansion. These can be selected to be indication, warning or shutdown inputs either immediate or held off during start up.

Uncommitted LED's allow additional annunciation.

Multiple alarm channels are provided to monitor the following:

- Under/Overspeed
- Charge Fail
- Emergency Stop
- Low oil pressure
- High engine temperature
- Fail to Start
- Fail to stop
- Loss of speed sensing
- Programmable inputs as selected

First-up alarm is indicated by a flashing LED. Subsequent simultaneous alarms are displayed by a steady LED.

The 500 series modules have been designed for front panel mounting. The module is fitted into the cut-out with the fixing clips removed. These are then fitted from the rear. Connection is via locking plug and socket connectors



DC Supply:

8 to 35 V Continuous.

Cranking Dropouts:

Able to survive 0 V for 50 mS, providing supply was at least 10 V before dropout and supply recovers to 5V. *This is achieved without the need for internal batteries.*

Max. Operating Current:

290 mA at 12 V. 210 mA at 24 V.

Max. Standby Current:

50 mA at 12 V. 30 mA at 24 V.

Alternator Input Range:

15 - 300 V ac RMS

Alternator Input Frequency:

50 - 60 Hz at rated engine speed.

Magnetic Input Range:

0.5 V to +/- 70 V (Clamped by transient suppressors)

Magnetic Input Frequency:

10Hz to 10,000 Hz

Start Relay Output:

16 Amp DC at supply voltage.

Fuel Relay Output:

16 Amp DC at supply voltage.

Auxiliary Relay Outputs:

5 Amp DC at supply voltage.

Dimensions:

96 X 96 X 140.5mm (Excluding switch)

Charge Fail / Excitation Range:

0 V to 35 V

Operating Temperature Range:

-30 to +70°C

CASE DIMENSIONS

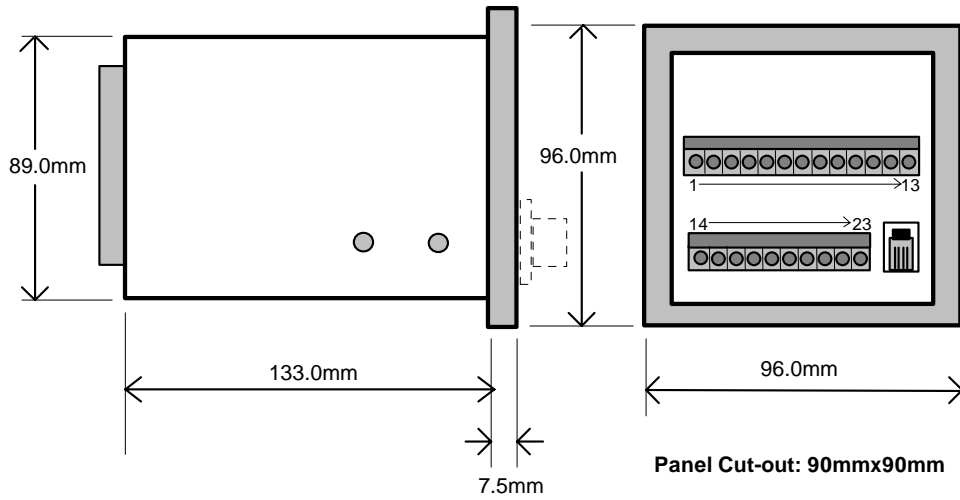

TYPICAL CONNECTIONS

