



DESCRIPTION

The 530 is a fully configurable **Automatic Transfer Switch control module**. It is designed to monitor the incoming AC mains supply (1 or 3 phases) for under/over voltage and under/over frequency. Should these fall out of limits, the module will issue a start command to the generating set controller. Once the set is available and producing an output within limits, the ATS module will control the transfer devices and switch the load from the mains to the generating set. Should the mains supply return to within limits the module will command a return to the mains supply and shut down the generator after a suitable cooling run. Various timing sequences are used to prevent nuisance starting and supply breaks.

Configuration is by PC based software and the 808 interface using an FCC68 socket on the rear of the module. This allows rapid and secure configuration of the module and also allows the 157 relay expansion module to be utilised. The FCC68 socket also provides full real-time diagnostics of inputs and outputs.

Configuration and connection options allow for a wide range of **higher functions** such as 'Auto start inhibit', 'Manual restore to mains', 'Load inhibit' (both mains and gen-set), 'Lamp test', Push-button transfer control, External mains or Gen-set failure inputs, etc.

The **four position key-switch** allows for mode selection:

- ▶ AUTO MODE
- ▶ AUTO MODE WITH MANUAL RETURN TO MAINS
- ▶ RUN GENERATOR OFF LOAD
- ▶ RUN GENERATOR ON LOAD

A clear mimic diagram, with International symbols and LED indications, provides 'at a glance' information as to supply availability and load switching status. Further LED indication is provided for 'Start delay in progress' and 'Mains return timer active'.

Two **user configurable LED's** are provided to allow the user to display specific states.

Five **user configurable relays** are provided to allow control of contactors, different breaker types and engine control modules and alarm systems.

The module features a **self seeking power supply** which will utilise power from the Mains AC supply or the Generator AC supply. A DC supply to the module is not essential for basic operation, though some 'higher' functions require it (such as breaker tripping).

The module is mounted in a robust plastic case and connection is via plug and socket connectors.

NOTE:

Relay output expansion for the 530 ATS module can be achieved using the 157 Relay Expansion Module.

SPECIFICATION

DC SUPPLY :

The 530 is normally powered from the AC sensing supplies. It will only draw power from the DC supply if both AC supplies are not present. The module DC is powered from the plant battery or from a low voltage supply between 8 to 35V Continuous. It is able to operate at 0V for 50ms during cranking, providing supply was at least 10V before dropout and supply recovers to 5V. This is achieved without the need for internal batteries.



MAX. OPERATING CURRENT :
150mA @ 12V, 95mA @ 24V.

MAX. STANDBY CURRENT(AC POWERED SUPPLY): 35 mA @ 115V. 16mA @ 230V.

3 LOW VOLTAGE AUXILIARY RELAY CONTACTS :

8Amp DC rated 1 each - NO/NC/CO.

2 MAINS RATED RELAY CONTACTS :

8Amp RMS rated 1 each NO/NC.

DIMENSIONS :

96 x 144 x 155 DIN STANDARD.

OPERATING TEMPERATURE RANGE :

-15 to +55°C

INDICATION LED's :

Mains Available/On Load, Generator Available/On load, Start Delay, Mains Return Delay and 2 User Configurable.

OPERATING VOLTAGE : - Specify on ordering.

AC Voltage Input Range (for AC Powered Operation):

115V Version:-88 - 160 V ac RMS

230V Version: 176 - 305 V ac RMS

AC Voltage Input/Adjustment Range (Sensing Operation):

115V Version: 55 - 152 V ac RMS

230V Version: 110 - 304 V ac RMS

AC Frequency Input/Adjustment Range:10 - 75 Hz

CASE DIMENSIONS

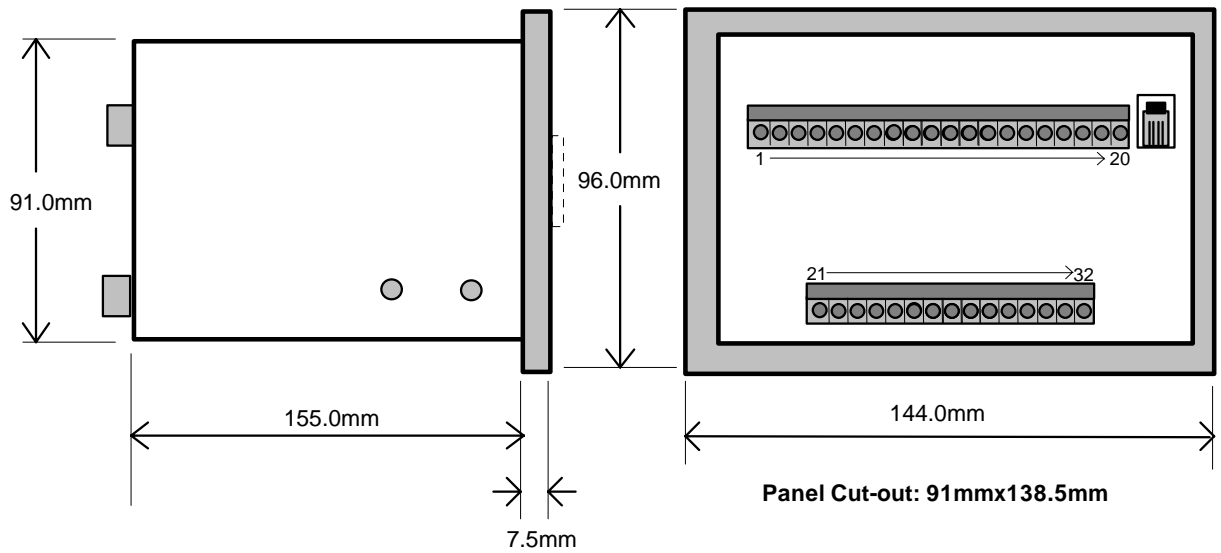

TYPICAL CONNECTIONS

