

# SDM72 Start on Demand Modules

Genset Controls - Timers - Monitors - Trips - Battery Charging - Spares & Accessories - Custom Products

## Application

Start-on-Demand (also known as Auto-on-Demand) enables base load applications to only operate when a demand for power is present. This system is typically used in remote locations - - -

- Farm Houses
- Hunting Lodges
- Pumping Stations

Although designed (and described here) for use with the RSM72 Remote-Start-Module, the SDM72 can easily interface with most (electric start) engine control systems







## Operation

- |              |   |
|--------------|---|
| Standby Mode | Plant stationary, the 'Green' standby Led indicates that the DC 'Excitation' voltage is connected to the (dead) AC Bus via term.32.   |
| Plant Run    | Whenever a load (with sufficiently low DC resistance, i.e. a 60W light bulb, central heating pump, refrigerator etc) is connected to the (dead) AC Bus, the red 'Demand' Led will indicate that a demand for power is present and that the Run Relay has energised. The volt-free contacts of this relay are used to start the engine via the RSM72 Remote Start Module or other suitable Engine Controller.<br>As the engine runs up to speed, the contactor control relay will energise once the alternator has attained a pre-set voltage for approx. 3 sec. Once energised, this relay cannot de-energise if the alternator voltage falls. If low voltage protection is required then an external voltage monitor will be required. |
| Plant Stop   | Load current is continually monitored via the (CT100S) current transformer to detect when the load falls below a pre-set level, typically 0.25A (a light bulb of 60W @ 230V / 30W @ 115V) for the 'Run On' (on Load) delay time. The contactor control relay will now de-energise; disconnecting the load and the set will stop after a pre-set delay of 10 sec. Subject to the loss of the AC voltage for a period of 5 sec (run-down timer) the SDM72 will revert to 'Standby Mode'.  |
| Manual Mode  | The 'Manual' input energises the Run relay, enabling the SDM72 to operate the contactor control relay when the engine is started manually from the RSM72.   |
| Low Battery  | The (optional) BVF300 Battery Voltage Monitor can be connected to term.30 of the SDM72 to indicate Low battery status and provide 'Demand' for power to start the set & / or prevent it from stopping in order to keep the batteries charged.<br>The BVF300 consists of two voltage trip-amps and their respective timers operating a relay via a 'flip-flop' latch. Thus, if the battery voltage remains below the 'Low' threshold for time 'T1', the latch will set, energising the relay. The engine will then run or remain running in order to charge its batteries via the charging alternator. When the battery voltage reaches the 'High' threshold for time 'T2', the latch will reset and the relay de-energise.              |

## CONNECTIONS

Always ensure that the correct wire sizes are used and that all terminals are tightened correctly.

Terminal	Description	Input / Output	Connect To -----
21 B+	+Ve Supply	Input	RSM72, Term.17 (Auto Mode +Ve O/P)
22 B-	- Ve Supply	Input	Battery -Ve
23 	Run Relay N/C contact	Volt Free Contact *	(not normally used )
24 	Run Relay C/O contact	Volt Free Contact *	RSM72, Term.17 (Auto +Ve O/P)
25 	Run Relay N/O contact	Volt Free Contact *	RSM72, Term.18 (Run, +Ve I/P)
26 MANUAL	Manual Input	+Ve Input	RSM72, Term.11 (Manual, +Ve O/P)
27 INT	'Interlock'	- Ve Input	RSM72, Term.14 (Alarm O/P)
28 Lamp Test	+Ve Lamp Test Supply	+Ve Input	Common 'Lamp Test' circuit
29 Alt. On Load	Alternator On Load Status	- Ve Input	Standby Contactor (n/o 'Aux.' contacts)
30 Low Battery	Low Battery Input	+ Ve Input	(Optional) BVF300 Batt. Volts Monitor
31 Relay	External Relay	- Ve Output ***	(See Text)
32 Load L	DC Excitation / Start Sensing	+ Ve In / Out **	(See Text)
33 C.T.	CT100S (secondary)	A.C. Input	(See Text)
34 C.T.		A.C. Input	(See Text)
35 	SCR Standby Control Relay	N/O Contacts *	Standby Contactor Coil
36 		N/O Contacts *	(See Text)
37 ALT. (L)	Alternator Voltage Sensing	A.C. Input	Main Alternator (270VAC max)
38 ALT. (N)	Alternator Voltage Sensing	A.C. Input	Main Alternator

NOTE : \* De-rate to 14% for Inductive Loads (2.2A for Relay or (Solenoid) see below

\*\* DC Excitation should be protected by an external fuse (see text).

\*\*\* Limit to 300mA Maximum. Flywheel diode(s) should be connected across inductive Load(s)

CT100S This special current transformer is supplied with the SDM72. It is suitable for all load currents (subject to the output cable diameter). However, if the SDM72 is to be used with a large or multi-set system we recommend that the CT100S is connected to an auxiliary load rather than the main load.

### **WARNING:** *Relay Contacts*

Although the on board relays are quite capable of directly switching small solenoids and contactor coils, we would recommend that slave relays are always used as a matter of course unless the Inrush & holding currents are known and are within the specification of the SDM72 contacts. In line with other manufacturers, we quote contact rating current for a resistive load. However, if the load is inductive (relay, solenoid , contactor coil or 'unknown') the quoted current must *always* be de-rated to 14%. Example: a quoted rating of 16A  $\equiv$  2.2A continuous current to allow for a 'seven times' inrush, when the inductive load is energised.

### **WARNING:** *Safety Circuit*

Although several levels of protection are provided, please ensure that the DC Excitation voltage on term.32 (sensing) is NEVER connected to a live (AC) Bus. Such action will permanently damage this module and possibly other equipment as Voltages **dangerous to human life** will be connected to the DC control circuits.

### **WARNING:** *Voltages dangerous to human life*

Voltages **dangerous to human life** may be present at some of the terminal connections of this unit. Ensure that all AC and DC supplies are isolated before attempting any connection / disconnection.

## A Typical Single Phase System

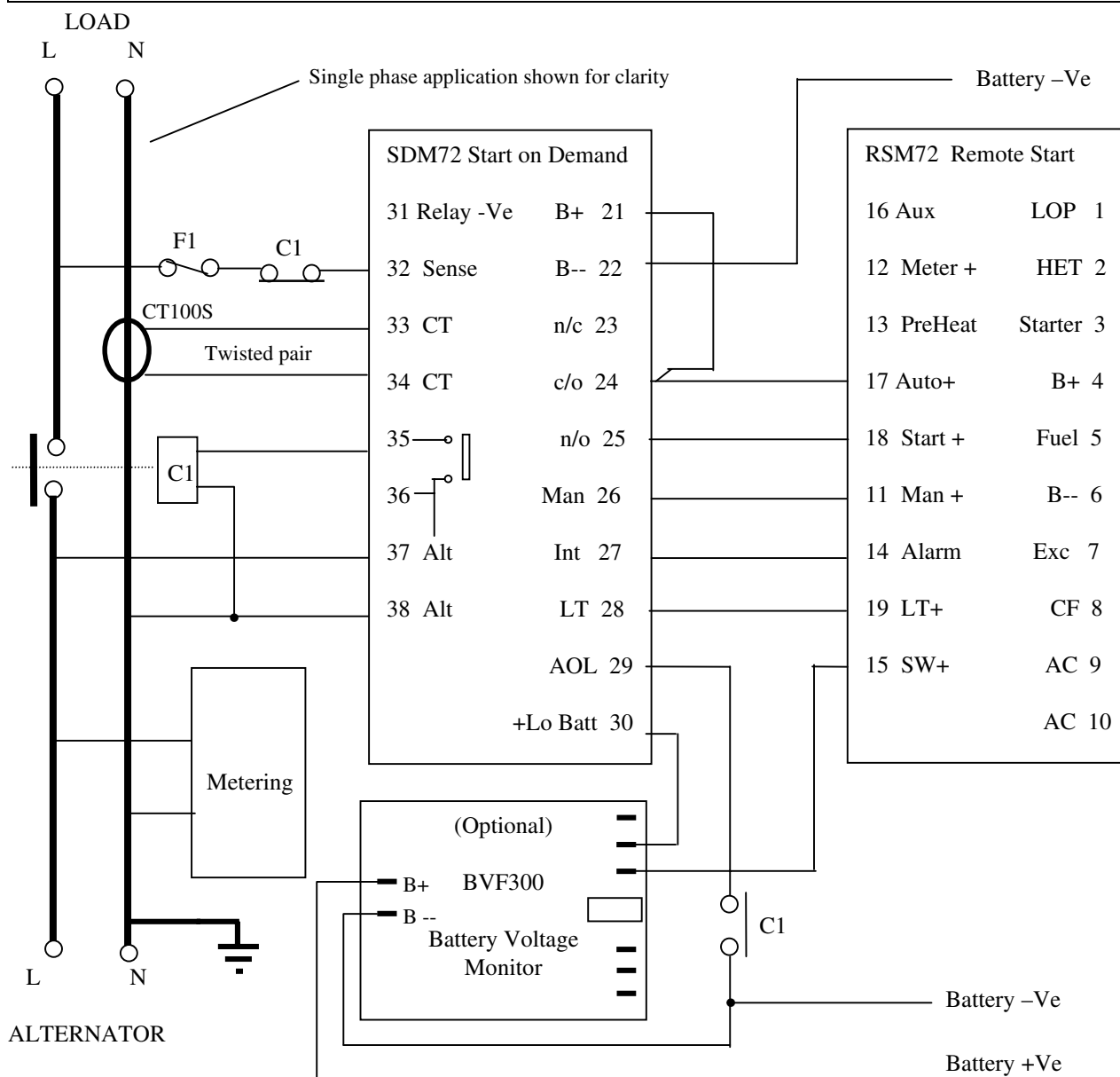

### SYSTEM DESIGN RULES

- Refer to the RSM72 'Data & Application Note' for generic Engine wiring, instructions & constraints.
- Refer to the BVF300 'Data & Application Note' if this part is to be used.
- Ensure that both the Alternator 'Neutral' and the Battery 'Negative' are bonded to Earth.
- Ensure that all metering is connected to the Alternator side of the Contactor
- **NEVER 'push' the contactor closed**
- Fuse 'F1' should be rated at 500mA Quick Blow
- Load Contactor 'C1' requires two auxiliary contacts (1 x n/o + 1 x n/c)
- Load Contactor 'C1' will require 3 poles in a 3 – phase application.

See overleaf for : output metering (i.e. kWh) & / or 3-Phase application

## OUTPUT METERING

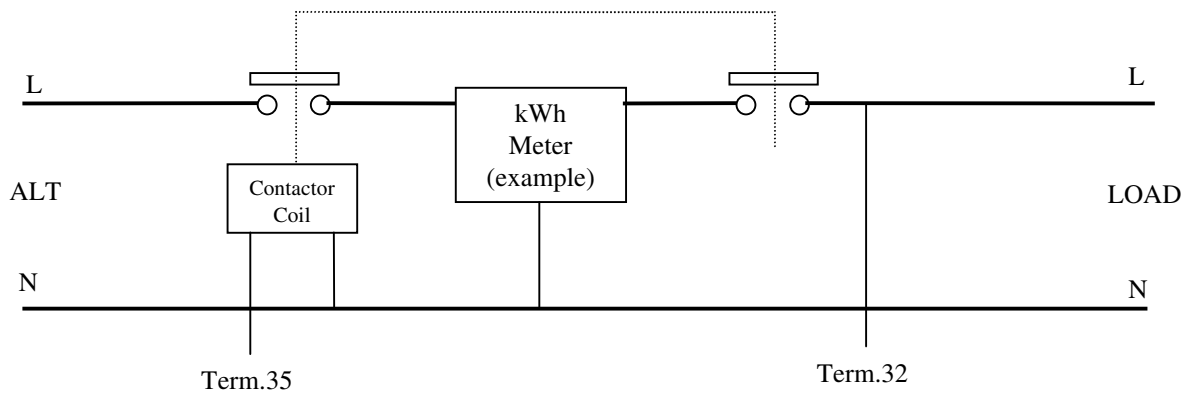

Single Phase shown for clarity

## 3 – PHASE APPLICATION

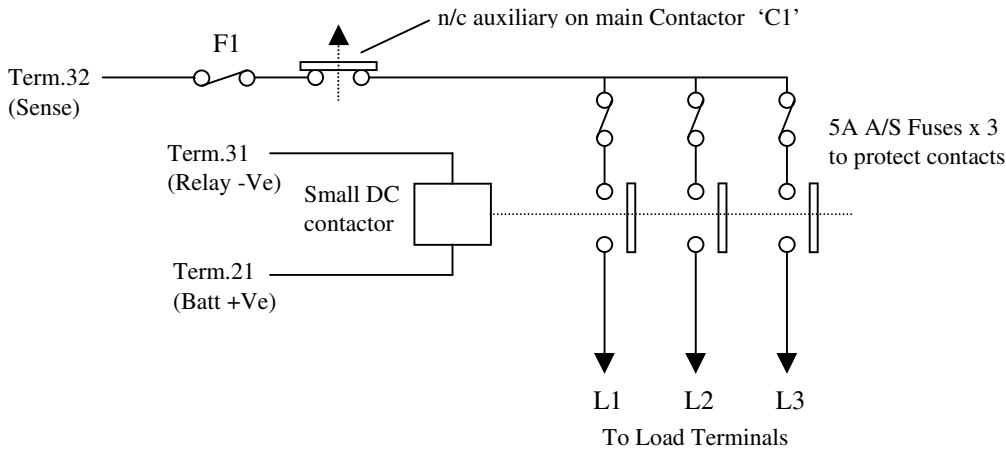

## ORDERING INFORMATION

Model No.	AC Volts L - N	Alternator Available	CT Type	Minimum Load	Delay Timers		
					Run-On	Stop	Safety
SDM72A/230	200 – 240	180V	CT100S	60W	4s – 4m	10s	5s
SDM72A/115	100 – 120	90V	CT100S	30W	4s – 4m	10s	5s
SDM72C	----- designed to order -----						

## SPECIAL BUILDS

**SDM72 - / - - / X0?** These 'X' numbers, indicate non-standard product, which has been manufactured to suit a specific customer. They do not appear in any catalogues and may only be available to the original customer. When re-ordering, please quote the full part number together with the 'Serial Number' of the original unit(s).

## CUSTOMISED PRODUCTS

If you have a specific requirement that is not listed above; please contact our Sales Desk for a quotation. We can normally customise a standard product within a matter of days in order to provide a prototype (if not, production) unit.



## SPECIFICATION

<b>CONSTRUCTION</b>	Through panel mounting, 72mm sq. DIN standard case Reverse screen printed "Lexan" front panel Printed circuit boards varnished as standard
<b>TEMPERATURE</b>	- 10°C to +55°C Operating - 25°C to +70°C Storage
<b>TERMINATIONS</b>	Industry Standard two piece connectors
<b>INDICATORS</b>	Five high intensity light emitting diodes (Led's) Load Demand (Red) Battery Voltage Low (Red) Alternator Available (Red) Alternator on Load (Red) Standby (Green)

<b>DC EXCITATION</b>	A 'mA' constant current source providing approx. + 8Vdc at term.32 ( to battery -Ve) when 'Standby' Led lit & no Load applied.
<b>START LEVEL</b>	Factory pre-set to suit the level attained (< 2 Vdc) with a 60W light bulb connected to the Load. <b>No adjustment should be required.</b>
<b>LOAD THRESHOLD</b>	Factory pre-set for 60W / 230V (or 30W / 115V) = 260mA, to maintain the load demand. <b>No adjustment should be required.</b>

<b>DELAY TIMERS</b>	Start Delay = fixed 1 sec Warm-Up Delay = fixed 3 sec 'Run-on (on Load) Time' = 4s - - 4mins, set at minimum. 'Stop Time' = fixed 10 sec Run Down Delay = fixed 5 sec
---------------------	---

**SUPPLY VOLTAGE** 12/24V single range supply. Burden = ?? mA (standby) at 12VDC

**CONTACT RATINGS** Run Relay = 16A (resistive). Contactor Control Relay = 5A /230VAC (resistive).

<h3 style="margin: 0;">Dimensions</h3>	<p><b>Notes:</b></p> <ul style="list-style-type: none"> <li>1/ Not to Scale</li> <li>2/ All dimensions in mm</li> <li>3/ Panel cut-out 68 x 68 mm</li> </ul>
--	--