

Power Drive Systems

Generator Control Specialists

48A Ainsdale Street
West Chermside, Qld 4032
Australia
email: info@powersystems.com.au

Telephone: 0500 800 225
Facsimile: 3350 1654
Mobile: 0427 22 00 18

P.O. Box 30
Grange, Qld 4051
Australia
www.powersystems.com.au

ADC100 SERIES

INTEGRAL ACTUATOR for STANADYNE "D" SERIES F.I. PUMPS

INTRODUCTION

The ADC100 Series Integral Actuator is designed to mount directly to Stanadyne "D" Series fuel injection pumps. When the ADC100 electric actuator is installed on the fuel pump, an integral high performance fuel control system results. No external linkages or brackets are required and no extra Stanadyne parts are needed. In addition, when the governor system is de-energized, the ADC100 Series electric actuator provides the function of a fuel shut off solenoid.

GAC employs its field proven electromechanical design which provides proportional actuator movement based on actuator coil current.

The ADC100 actuator is simple to install. It conveniently replaces the fuel injection pump mechanical governor cover to achieve an integrated proportional servo fuel control package.

SYSTEM DESCRIPTION

The actuator is an electromagnetic servo device which can be integrated into a closed loop fuel control system. An engine speed control system can be described as follows. Electrical signals are generated by a magnetic speed sensor which are proportional to engine speed. The signal is sent into the electronic speed control unit which compares it to the preset engine speed setting. If the magnetic speed sensor signal and the preset engine speed are not equal, a change in current from the speed control unit to the actuator will change the magnetic force to the actuator. The rotation of the actuator shaft will then adjust the engine speed to be equal to the preset engine speed setting. Shaft rotation is proportional to the amount of actuator current and counterbalanced by the actuator's return spring.

Since the design has no sliding parts and is sealed, outstanding reliability results. No maintenance is required.

SPECIFICATIONS

POWER INPUT

Operating Voltage (Dedicated Coil)	12 or 24 VDC available
Nominal Operating Current	1.9 A at 12 VDC
.....	1.5 A at 24 VDC
Maximum Current (Continuous).....	2.7 A at 12 VDC
.....	1.9A at 24 VDC

ENVIRONMENTAL

Operating Temperature Range.....	-40° to +180°F (-40° to +85°C)
Relative Humidity.....	up to 100%
All Surface Finishes.....	Fungus Proof and Corrosion Resistant

PHYSICAL

Dimensions.....	See Diagram 1
Weight.....	2.2 lbs (1 Kg.)
Mounting.....	Directly on STANADYNE "D" Series fuel injection pumps

RELIABILITY

Testing	All Units 100% Tested to GAC Specifications #TS1526
---------------	---

MATING HARDWARE

Wiring Harness – (2 Wire with Automotive Connector included w/Actuator).....	CH1215
--	--------

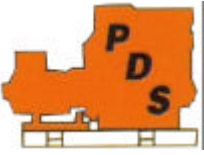

Power Drive Systems

Generator Control & UPS Specialists

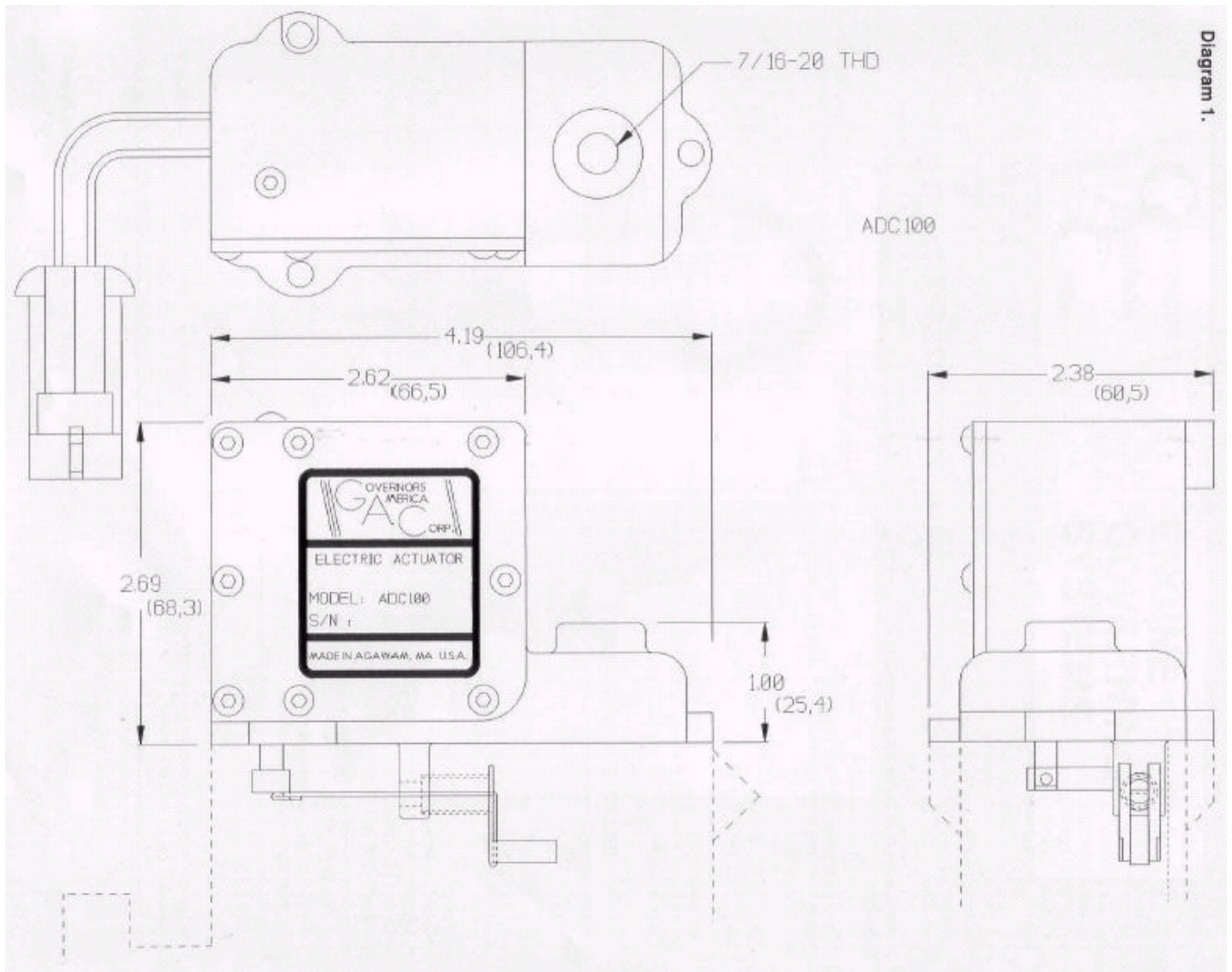

INSTALLATION

PREPARING THE FUEL PUMP

Before the fuel injection pump's Governor Cover can be removed and replaced by the ADC100 Series electric actuator, it is important for the outside of the pump to be clean. If necessary, remove any dirt with a solvent. This will prevent contaminants from entering the pump. The cleaning solvents as well as fuel oil can be collected by placing a suitable container underneath the pump.

1. Disconnect the pump's Electric Shutoff Solenoid wire from its connection point on the pump's Governor Cover. This wire connection is no longer necessary and it can be eliminated at its source.
2. Remove the Fuel Return Line from the Fuel Return Line Connector.
3. Remove the three (3) Governor Cover Screws. These will be replaced by mounting screws provided with the ADC100 Series Actuator.
4. Remove the Governor Cover assembly with care, to insure that no dirt is allowed to enter the fuel injection pump.
5. Remove the Fuel Return Line Connector and the Gasket from the Governor Cover Assembly. Save the Gasket for later assembly use with the ADC 100 electric actuator.

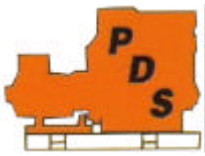

Power Drive Systems

Generator Control & UPS Specialists

INSTALLING THE ACTUATOR

1. Install the supplied straight Fuel Return Line Connector and original pump Gasket to the ADC100 electric actuator.
2. Position the ADC100 electric actuator on the fuel injection pump with the tall end of the electric actuator tilted slightly upward. See Diagrams 1 and 2.
3. Slide the ADC100 electric actuator toward the drive end of the fuel injection pump until the actuators' U shaped coupler engages the pump's Governor Linkage Hook. After engagement has been made, align the mounting holes between the electric actuator and the fuel injection pump.

CAUTION:

Improper engagement of the actuator coupler to the pump's Governor Linkage hook can cause an engine overspeed condition.

4. Securely fasten the ADC100 electric actuator to the fuel injection pump, using the (3) screws provided with the actuator.
5. Re-attach the Return Fuel Line to the Fuel Return Line Connector seated on the ADC100 electric actuator.

FUEL INJECTION PUMP SET-UP

Prior to starting the engine, the pump's shut off lever, throttle lever and mechanical governor must be set, to insure compatibility with the electronic governor.

1. Secure the shut off lever in the "On Fuel" position, if the Stanadyne pump is quipped with one.
2. Lock the throttle lever in the High idle fuel setting position. This setting should be 10-12% above the desired governor speed.
3. Adjust the pump's mechanical governor Droop by turning the Droop Adjusting Screw counterclockwise (CCW) until it stops. Then turn it clockwise (CW) two turns. This adjustment will provide compatibility between the mechanical governor and the electronic governor. See Diagram 2.

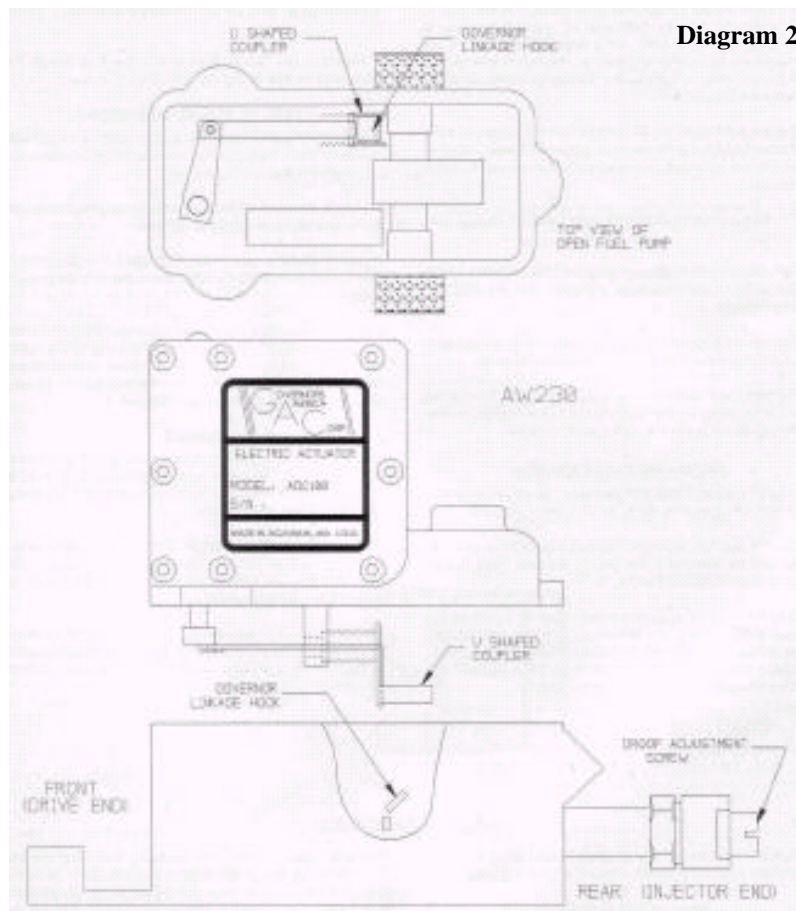

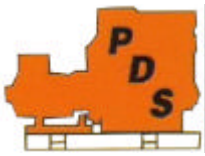

James Hamilton Electrical Pty Ltd (Inc in Qld) A.C.N. 010 848 389 trading as

Power Drive Systems

Generator Control & UPS Specialists

WIRING

The ADC100 Series is designed to have a dedicated coil for use in the 12 VDC operation and another dedicated coil for 24 VDC operation. These actuators are respectively identified as ADC100-12 and ADC100-24.

The output from the selected GAC speed control unit is connected to the ADC100 Series Actuator using the GAC cable harness CH1215. See the specific speed control unit literature for wiring information.

CH1215 includes the pre-wired actuator mating half connector for the ADC100 Series actuator. The actuator connector offers a vibration resistant and environmentally sealed electrical connection.

TROUBLESHOOTING

If the governor system fails to operate and the actuator is suspected to be the problem, make the following tests.

Measure Coil Resistance

3.0 ohms	12VDC
7.5 ohms	24 VDC

Measure Coil Isolation

>1M ohm to ground

Remove actuator cover and manually move the actuator through its range by depressing the actuator's armature. Energize the actuator to full fuel (follow steps in control unit publication). No binding or sticking should occur. Install new gasket (GA100) and replace actuator cover.

If the actuator passes these tests, the problem is elsewhere in the governor system. Refer to the speed control unit troubleshooting publication.